



**EUROPEAN NEW CAR ASSESSMENT PROGRAMME  
(Euro NCAP)**



**ASSESSMENT PROTOCOL – CHILD OCCUPANT PROTECTION**

Version 5.1  
October 2009

# EUROPEAN NEW CAR ASSESSMENT PROGRAMME (Euro NCAP)

## ASSESSMENT PROTOCOL – CHILD OCCUPANT PROTECTION

### Table of Contents

<b>1</b>	<b>INTRODUCTION</b> .....	<b>3</b>
<b>2</b>	<b>METHOD OF ASSESSMENT</b> .....	<b>3</b>
<b>3</b>	<b>CHILD PROTECTION ASSESSMENT</b> .....	<b>5</b>
<b>3.1</b>	<b>Introduction</b> .....	<b>5</b>
<b>3.2</b>	<b>Preconditions</b> .....	<b>5</b>
<b>3.3</b>	<b>Dynamic Assessment</b> .....	<b>5</b>
3.3.1	Ejection .....	6
3.3.2	Head Contact with the Vehicle .....	6
3.3.3	Frontal Impact.....	6
3.3.4	Side Impact .....	8
<b>3.4</b>	<b>CRS Based Assessment</b> .....	<b>8</b>
3.4.1	CRS Marking .....	8
3.4.2	CRS to Vehicle Interface .....	12
<b>3.5</b>	<b>Vehicle Based Assessment</b> .....	<b>12</b>
3.5.1	Use of CRS on the Front Seat .....	13
3.5.2	Provision of Three-point Seat Belts .....	15
3.5.3	Gabarit .....	15
3.5.4	All Passenger Seats Suitable for Universal CRS .....	17
3.5.5	ISOFIX .....	17
3.5.6	Integrated CRS.....	18
<b>3.6</b>	<b>Scoring and Visualisation</b> .....	<b>19</b>
3.6.1	Scoring.....	19
3.6.2	Child Protection Assessment Points Table (Normal and Limited Rear Space) .....	20
3.6.3	Child Protection Assessment Points Table (No Rear Seats) .....	21
3.6.4	Visualisation .....	22
<b>4</b>	<b>CONCEPTS AND EXPLANATIONS BEHIND THE ASSESSMENTS</b> .....	<b>23</b>
<b>4.1</b>	<b>Dynamic Assessment</b> .....	<b>23</b>
4.1.1	Ejection (section 3.3.1) .....	23
4.1.2	Frontal Impact.....	23
4.1.3	Side Impact .....	23
4.1.4	Head Containment (Section 3.3.4.1).....	23
<b>4.2</b>	<b>CRS Based Assessment</b> .....	<b>23</b>
4.2.1	CRS Marking (Section 3.4.1).....	23
4.2.2	CRS to Vehicle Interface (Section 3.4.2).....	23
<b>4.3</b>	<b>Vehicle Based Assessment</b> .....	<b>24</b>
4.3.1	Use of CRS on Front Seat .....	24
4.3.2	Provision of Three-point Seat Belts (Section 3.5.2) .....	24

4.3.3	Gabarit (Section 3.5.4).....	24
4.3.4	All Passenger Seats Suitable for Universal CRS (Section 3.5.4).....	24
4.3.5	ISOFIX .....	24
4.3.6	Integrated CRS.....	25
<b>5</b>	<b>REFERENCES .....</b>	<b>26</b>
	<b>APPENDIX I.....</b>	<b>27</b>
	<b>APPENDIX II.....</b>	<b>28</b>

# **EUROPEAN NEW CAR ASSESSMENT PROGRAMME (Euro NCAP)**

## **ASSESSMENT PROTOCOL – CHILD OCCUPANT PROTECTION**

### **1 INTRODUCTION**

Euro NCAP's original assessment protocol was developed jointly by TRL and Vehicle Safety Consultants Ltd. under contract to the UK Department of the Environment Transport and the Regions and International Testing, respectively. Subsequent versions of the protocol have been developed and released by the Euro NCAP Secretariat. Beginning with Version 5 important changes have been included that have been brought about by the introduction of the overall rating scheme. Individual documents are released for the four main areas of assessment:

- Assessment Protocol – Adult Occupant Protection;
- Assessment Protocol – Child Occupant Protection;
- Assessment Protocol – Pedestrian Occupant Protection;
- Assessment Protocol – Safety Assist;

In addition to these four assessment protocols, a separate document is provided describing the method and criteria by which the overall safety rating is calculated on the basis of the car performance in each of the above areas of assessment.

The following protocol deals with the assessments made in the area of Child Occupant Protection for vehicles with a second row or more and for vehicles with limited rear space.

**DISCLAIMER:** Euro NCAP has taken all reasonable care to ensure that the information published in this protocol is accurate and reflects the technical decisions taken by the organisation. In the unlikely event that this protocol contains a typographical error or any other inaccuracy, Euro NCAP reserves the right to make corrections and determine the assessment and subsequent result of the affected requirement(s).

### **2 METHOD OF ASSESSMENT**

The starting point for the assessment of child occupant protection is the dummy head response data recorded in frontal impact and side impact. For this purpose two crash dummies, representing a 1½ year old and 3 year old child are placed in child seats recommended by the car manufacturer. The dynamic assessment focuses on head and chest only due to the limited biofidelity of the dummies for other body regions. At post-crash vehicle inspection, additional assessments are done on the CRS with respect to marking and the way the seats interface with the car. Similarly, the car is assessed on aspects as labelling, airbag disabling, ISOFIX usability amongst others. The scores achieved in the three main categories are combined to calculate the total Child Occupant Protection Score.

Cars with limited or no rear space such as two seaters do not allow a typical dynamic assessment using dummies in the rear. For these classes of vehicles, special provisions have been made to the protocol.

## **3 CHILD PROTECTION ASSESSMENT**

### **3.1 Introduction**

This protocol defines how protection for 1½ year old and 3 year old children is assessed in Euro NCAP, using P Series dummies for dynamic performance. The protocol described below is applicable to all classes of vehicles currently assessed by Euro NCAP, including vehicles where there is no rear bench or where there is limited space for carrying Child Restraints (CRS) on the rear seats.

### **3.2 Preconditions**

3.2.1 The CRS must be recommended by the vehicle manufacturer, to their customers, in all countries of the European Union, where the vehicle is sold.

3.2.2 The CRS must be available for purchase by the public, in all countries of the European Union, where the vehicle is sold. The CRS system must be available to the public within 5 working days of an order being made.

3.2.3 The CRS must be formally approved to UN ECE Regulation 44.04 or later, for the vehicle being assessed.

3.2.4 For vehicles with limited space in the rear which cannot accommodate the usual CRS recommended by the manufacturer, a more suitable alternative CRS shall be recommended. These seats must fit in the vehicle with the front seats in the test position.

3.2.4.1 Where the manufacturer makes no recommendation or the alternative seats do not fit in the vehicle, Euro NCAP will choose any suitable CRS which can be installed in the vehicle for use in the crash test. Where this is the case, the points for CRS to Vehicle Interface will not be awarded.

3.2.4.2 Where it is not possible to install any CRS (either recommended or randomly chosen CRS) on the rear seats with the front seats in the test position, the vehicle will be assessed as normal but the dynamic and compatibility assessments will be defaulted to **zero points**. If the manufacturer wishes to avoid being awarded zero points for the dynamic and compatibility assessments, section 3.3 below details alternative requirements for this scenario.

### **3.3 Dynamic Assessment**

This section is only applicable to vehicles equipped with rear seats; the preconditions for dynamic assessments are detailed in section 3.2 of this document.

Where a manufacturer wishes to avoid being awarded zero points for the CRS dynamic and compatibility assessments, data from additional full scale frontal and side impact tests may be provided by the manufacturer. These tests shall be performed using the appropriate CRS with the front seats positioned as required to allow for installation of the CRS. This front seat position should be mentioned in the vehicle handbook.

The tests must be equivalent to the Euro NCAP front and side impact tests and contain an equivalent level of instrumentation. Adult dummies are not required. It is the responsibility of the vehicle manufacturer to ensure that adequate film coverage of the impact, and specifically child head excursion and head containment, is provided.

A hybrid rating would be produced using the adult data from the normal full scale test (performed without CRS) and the child data from the additional tests. In the final vehicle rating, Euro NCAP will indicate that it was not possible to install the CRS with and adult in the normal Euro NCAP front seat test position.

### 3.3.1 Ejection

3.3.1.1 If the child dummy is ejected or partially ejected from the CRS at any time throughout the impact including rebound, that CRS is awarded **zero points** for its dynamic performance in front and side impact. Otherwise, points are awarded as given below.

3.3.1.2 If the CRS is partially or wholly unrestrained by any of the vehicle interfaces at any time throughout the impact including rebound, that CRS is awarded **zero points** for its dynamic performance in front and side impact. The vehicle interfaces of ISOFIX restraints are the two ISOFIX anchorages, top tether anchorage or any other means of rotation limiting device such as a support leg. Seat belt lock-offs, tethers, straps or any other attachments which are specifically used to anchor the CRS to the vehicle will also be penalised, if their failure presents a risk of total or partial ejection of the child or child restraint. Where the CRS is fully restrained throughout the impact, points are awarded as given below.

### 3.3.2 Head Contact with the Vehicle

3.3.2.1 If there is head contact with any part of the vehicle at any time throughout the impact including rebound, the CRS containing that dummy is awarded **zero points** for its head and neck performance, in that test. Otherwise, points are awarded as given below.

### 3.3.3 Frontal Impact

#### 3.3.3.1 *Head Contact with the CRS*

Contact is defined by either:

- a) Direct evidence of contact
- b) Peak resultant acceleration > 80g

In the absence of contact:

P1½ is awarded **2 points**

P3 is awarded **4 points**

In the presence of contact, the score is based on the Head Resultant Acceleration, 3msec exceedence. Hard contacts occurring during the head rebound will not be considered.

P1½ **2 points** ≤ 72g; **0 points** ≥ 88g

P3 **4 points** ≤ 72g; **0 points** ≥ 88g

*Note: Between limit values, a sliding scale will be used, for this and other parameters.*

#### 3.3.3.2 Head Excursion (Forward Facing CRS)

Where possible the maximum forward excursion of the head, relative to the Cr point, is estimated. If the forward excursion cannot be estimated, it will be deemed to be ≤ 549mm; otherwise the points will be based on the following:

P1½ **2 points** ≤ 549mm; **0 points** ≥ 550mm

P3 **4 points** ≤ 549mm; **0 points** ≥ 550mm

If in future a more precise method of measuring head excursion becomes available, a sliding scale may be introduced. Again, in future, consideration may be given to basing the limits on internal geometry of the vehicle.

#### 3.3.3.3 Head Exposure (Rearward Facing CRS)

Where the following requirements are complied with, the P1½ will be awarded **2 points** and the P3 will be awarded **4 points**.

a) No compressive loads shall be applied to the top of the head.

b) The head must remain fully contained within CRS shell, during the forward movement of the dummy (i.e. the top of the head must not be exposed to the possibility of direct contact with parts of the vehicle)

#### 3.3.3.4 Neck Tension (Rearward Facing CRS)

As a surrogate for neck tension, the score is based on the Head Vertical Acceleration, 3msec exceedence.

P1½ (only) **2 points** ≤ 20g; **0 points** ≥ 40g

*Note: With the neck transducer now available, forces will be measured directly and may be used in the future.*

#### 3.3.3.5 Chest

The chest score is based on the worst scoring of the two parameters, as detailed below.

Chest resultant acceleration, 3msec exceedence

P1½ and P3 **4 points** ≤ 41g; **0 points** ≥ 55g

Absolute value of chest vertical acceleration, 3 msec exceedence

P1½ and P3 **4 points** ≤ 23g; **0 points** ≥ 30g

### 3.3.3.6 Overall Dynamic Score for Frontal impact

The Overall Dynamic Score for the Frontal Impact is calculated as:

$$\begin{aligned} & \text{Worst score from } \left( \begin{array}{l} \text{Head Contact with the CRS (Section 3.3.3.1)} \\ \text{Head Excursion (Section 3.3.3.2)} \\ \text{Head Exposure (Section 3.3.3.3)} \end{array} \right) \\ & + \text{Score from Neck Tension (Section 3.3.3.4)} \\ & + \text{Score from Chest (Section 3.3.3.5)} \end{aligned}$$

### 3.3.4 Side Impact

#### 3.3.4.1 Head Containment

If the head is not contained within the shell of the CRS at any time throughout the impact including rebound, the CRS containing that dummy is awarded **zero points**. Otherwise, points are awarded as given in section 3.3.4.2 below.

*Note: "Contained" requires that some energy absorbing section of the side wing remains between the head and a virtual intruding vertical plane, representing the side structure of the vehicle. There must also be no fracturing of the CRS which might compromise the performance of the side wing of the CRS.*

#### 3.3.4.2 Head Contact with the CRS

Contact is defined by either:

- a) Direct evidence of contact
- b) Peak resultant acceleration > 80g

In the absence of contact:

P1½ and P3 are awarded **4 points**

In the presence of contact, the score is based on the Head Resultant Acceleration, 3msec exceedence.

P1½ and P3 **4 points** ≤ 72g; **0 points** ≥ 88g

## 3.4 CRS Based Assessment

This section is applicable to all child seats assessed, including those that have been chosen by Euro NCAP where the manufacturer has made no (suitable) recommendation for specific child seats.

### 3.4.1 CRS Marking

If the markings on the CRS fully comply with the following "CRS Marking Requirements" and the relevant "Additional CRS Marking Requirements," that CRS will be awarded **4 points**. Otherwise it will be awarded **zero points**.

Where a CRS, or part of a CRS, is approved for use in different configurations, Euro

NCAP will assess the marking for each configuration. Points will only be awarded if the requirements are met for all approved configurations.

The CRS markings must fully comply with the following requirements of UN ECE Regulation 44, Revision 2 [1]. As these requirements may be updated, so consideration will be given to updating the Euro NCAP requirements with the aim of avoiding conflict.

*Note: The paragraph numbers below are those of the UN ECE Regulation 44 Rev2 [1].*

§4.3 If the restraint is to be used in combination with an adult safety belt the correct routing of the webbing shall be clearly indicated by means of a drawing permanently attached to the restraint. If the restraint is held in place by the adult safety-belt, the routes of the webbing shall be clearly marked on the product by colour coding. The colours for the safety-belt route to be used when the device is installed forward facing shall be red and when installed rear-facing shall be blue. The same colours shall also be used on the labels on the device that illustrate the methods of use.

There must be a clear differentiation between the intended routes for the lap section and the diagonal section of the safety belt. Indication such as colour coding, words, shapes etc. shall distinguish each section of the safety belt.

In any illustration of the belt route on the product, the orientation of the child restraint relative to the vehicle must be clearly indicated. Belt route diagrams that do not show the vehicle seat are not acceptable.

The marking defined in this paragraph shall be visible with the restraint in the vehicle. For group 0 restraints, this marking shall also be visible with the child in the restraint.

§4.4 On the visible inner surface (including the side wing beside the child's head) in the approximate area where the child's head rests within the child restraint, rearward facing restraints shall have the following label permanently attached (the text information shown is a minimum).

This label shall be provided in the language(s) of the country where the device is sold.

Label minimum size: 60 x 120 mm

The label shall be stitched to the cover around its entire perimeter and/or permanently bonded to the cover over its entire back surface. Any other form of attachment that is permanent and not liable to removal from the product or to becoming obscured is acceptable. Flag type labels are specifically prohibited.

If sections of the restraint or any accessories supplied by the child restraint manufacturer are able to obscure the label an additional label is required. One warning label shall be permanently visible in all situations when the restraint is prepared for use in any configuration.

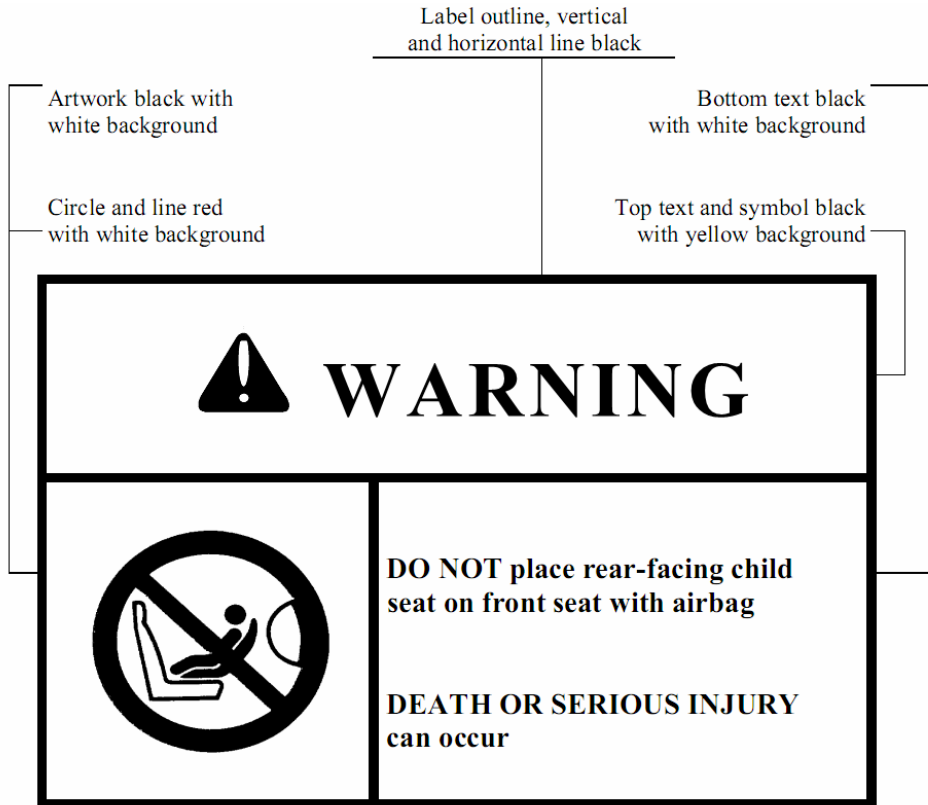

§4.5 In the case of child restraints that can be used forward and rear-facing, include the words:

"IMPORTANT - DO NOT USE FORWARD FACING BEFORE THE CHILD'S WEIGHT EXCEEDS ..... (Refer to instructions)"

§4.6 In the case of child restraints with alternative belt routes, the alternative load bearing contact points between the child restraint and the adult safety-belt must be permanently marked. This marking shall indicate that it is the alternative belt route, and shall conform with the above coding requirements for forward and rearward facing seats.

§4.7 If the child restraint offers alternative load bearing contact points, the marking required in paragraph 4.3 shall include an indication that the alternative belt route is described in the instructions."

In addition, Euro NCAP has the following requirements:

- a) The markings must be permanently marked on the CRS.
- b) These markings must be easily visible to a user installing the CRS from either side of the CRS. Any relevant information must be easily visible, at the time an installation action is to be performed.
- c) These markings must show how all the required CRS components are used for each size of child.

#### 3.4.1.1 *Additional Marking Requirements (ISOFIX)*

- a) The markings on the CRS must show how the ISOFIX attachments should be used.
- b) These markings must indicate how the seat should be prepared for installation. This must include information on how the ISOFIX latch system is extended.
- c) These markings must indicate the position, function and meaning of any “tell tales.”
- d) These markings must indicate the position and method of use of the “top tether” or other means of limiting CRS rotation.
- e) These markings must indicate how the ISOFIX latch system, top tether or other means of limiting CRS rotation are to be adjusted.
- f) The markings must also meet the requirements for “vehicle specific” child restraints.
- g) For Universal ISOFIX, the markings must indicate the following:
  - That the CRS should only be used on seats provided with a top tether and be approved for use with three-point Universal ISOFIX.
  - That use on seats without a top tether should be avoided.
  - That the top tether is an essential part of the restraint system.
- h) For Semi-universal ISOFIX, the markings must indicate the following:
  - That the CRS should only be used in combination with an “anti-rotation device” and be approved for use with an anti-rotation device.
  - Advice on how to use and adjust the anti-rotation device.
  - That the anti-rotation device is an essential part of the restraint system.

#### 3.4.1.2 *Additional Marking Requirements (Vehicle Specific and Semi-universal ISOFIX)*

- a) Seats approved as Vehicle Specific or Semi-universal ISOFIX must have the following additional information clearly and permanently displayed on the seat. The content is important, the specific wording of the second and third items is not:
  - Attention: This child seat is only approved for use in certain models of vehicle.
  - A list of suitable models of vehicle is contained in or attached to the instruction manual for the CRS.
  - Information on how to obtain the latest information regarding suitable vehicles.

(e.g. web site address, telephone or fax number.)

- b) The vehicle specific list, current at the time of production, must be contained in or attached to the instruction manual for the CRS.
- c) The text must be in at least one of the languages of the country in which the CRS is sold.

### 3.4.2 CRS to Vehicle Interface

For the outboard rear seating positions, compatibility is assessed for all combinations of CRS and vehicle adjustment unless they are specifically excluded, as indicated by permanent markings on the seat or on the vehicle. Such markings must be clearly visible to the user installing the CRS. Currently, this assessment does not assess space requirements.

Where there are no compatibility issues, the CRS is awarded **two points**. Otherwise, **zero points** are scored.

#### 3.4.2.1 *Additional Interface Requirements (Universal CRS)*

Examples of incompatibility:

- a) Adult belt hardware which is loaded in bending, due to the interaction between the buckle and seat belt contact point.
- b) Adult belt geometry where the belt anchorage is forward of the seat belt contact point. This allows excessive forward movement of the CRS, before tension is generated in the adult belt.

#### 3.4.2.2 *Additional Interface Requirements (ISOFIX and other CRS)*

Examples of incompatibility:

- a) Inadequate support provided for a leg used to supplement restraint of the CRS.
- b) ISOFIX seats where predictable mis-latching situations are identified. Mis-latching may be related to the ISOFIX interface attachments or any latching between the CRS seat and its mounting frame or support leg.

To avoid mis-latching:

- (i) The CRS markings must include instructions to physically check that the latches are engaged e.g. by pulling on the CRS, and
- (ii) A visual tell tale or tell tales must indicate when the latches are correctly locked. The tell tale(s) must be easily visible to a user installing the CRS.

## 3.5 **Vehicle Based Assessment**

This section is applicable to all vehicles assessed by Euro NCAP.

### 3.5.1 Use of CRS on the Front Seat

#### 3.5.1.1 *Airbag Warning Marking*

If the vehicle is fitted with a front seat passenger's frontal protection airbag and an airbag warning marking exists which fully complies with the following requirements, **2 points** are awarded to the Child Protection score.

If no airbag is fitted to the model variant tested by Euro NCAP but it is available as an option, the assessment will be carried out on a vehicle with the optional airbag fitted. If no airbag is available the **2 points** will be awarded to the Child Protection score, irrespective of the presence of a warning label.

- a) The label must contain text and a pictogram warning of the hazard associated with the use of a rearward facing CRS on a seat equipped with a frontal protection airbag. The ISO pictogram is preferred as it should be used on the CRS.
- b) The text must be in at least one of the languages of the country in which the vehicle is sold.
- c) The text must refer to "death and serious injury" as a possible consequence of ignoring the advice.
- d) The label must be of conspicuous design and it must be permanently visible.
- e) The label must be permanently attached to the vehicle but not to the windscreen, which may be replaced during the life of the vehicle.

#### 3.5.1.2 *Airbag Disabling Requirements*

If the vehicle is equipped with a system which automatically detects the presence of ANY rearward facing CRS and obviates any risk associated with airbag deployment, **3 points** are awarded to the Child Protection score. Such a system must re-activate the airbag when the CRS is removed.

If no front seat passenger's frontal protection airbag is fitted to any variant in the model range, **2 points** are awarded to the Child Protection score. If the airbag is optional, the assessment will be based on a vehicle fitted with the optional airbag.

If a front seat passenger's frontal protection airbag is fitted and the following requirements are complied with, **2 points** are awarded to the Child Protection score.

- a) Dealer disconnect is available for vehicles with rear seats.  
*Note: This is not an acceptable disconnection measure for car without rear seats such as two seaters, which would be awarded no credit.*
- b) The airbag can be de-activated by a manual switch meeting the following requirements:
  - Easily visibly information and warnings must be provided for the driver and front seat passenger, showing the status of the airbag.

- Text must be in at least one of the languages of the country in which the vehicle is sold. Alternatively, the words ‘Passenger AIRBAG OFF/ON’ are acceptable where the requirements of 3.5.1.1 are also met.

*Note: ‘Pass’, ‘AB’ or other abbreviations are NOT acceptable.*

- Pictograms are required to indicate the airbag status (ON and OFF).
- If the information to indicate that the airbag is enabled is provided by an illuminated signal, the signal is only required to be illuminated for a period of 60 seconds after the ignition is switched on. The AIRBAG ON pictogram must be the same as that used in the airbag warning label (section 3.5.1.1).
- Information to indicate that the airbag is disabled must be permanently displayed, when the ignition is on.
- The switch must be accompanied by text in at least one of the languages of the country which the vehicle is sold. Alternatively, the switch may be labelled with the text ‘Passenger AIRBAG OFF/ON’ providing it has also been used for the airbag status warning.
- The individual switch positions must be marked with the same pictograms that are used to indicate that airbag status. However, they need not be illuminated on the switch.
- Any labelling/instructions must be permanently attached to the vehicle. The switch labelling/instructions must be adjacent to the switch itself and clearly visible at the time of activation/deactivation.
- The information provided must be clear, without reference to the vehicle’s handbook or other source.
- There must be no possibility of the users being given false information.
- If, with the ignition on and with engine running or not, the switch position can be changed, the system must react correctly to the change immediately. Systems will be checked once the vehicle diagnostics/system checks have been completed.
- If at any time the airbag is switched from the OFF position to the ON position, the status indicator showing that the airbag is ON must signal this immediately for at least 60 seconds, regardless of the length of time the ignition has been switched on, or until the ignition is switched off again.

*Notes:*

*Where Euro NCAP refers to the airbag deactivation components as ‘the system’, this refers to the switch, airbag status indicator, airbag any other components associated with the deactivation of the airbag.*

*If ‘dealer disconnect’ is available for a car fitted with a ‘manual or automatic switch’, the requirements for the switch must also be met for the points to be awarded.*

- c) The airbag can be de-activated by an automatic switch/system meeting the following requirements:

- Easily visibly information and warnings must be provided for the driver and front seat passenger, showing the status of the airbag.
- Text must be in at least one of the languages of the country in which the vehicle is sold. Alternatively, the words ‘Passenger AIRBAG OFF/ON’ are acceptable where the requirements of 3.5.1.1 are also met. Note: ‘Pass’, ‘AB’ or other abbreviations are NOT acceptable.
- Pictograms are required to indicate the airbag status (ON and OFF).
- If the information to indicate that the airbag is enabled is provided by an illuminated signal, the signal is only required to be illuminated for a period of 60 seconds after the ignition is switched on. The AIRBAG ON pictogram must be the same as that used in the airbag warning label (3.5.1.1)
- Information to indicate that the airbag is disabled must be permanently displayed, when the ignition is on.
- Any labelling/instructions must be permanently attached to the vehicle.
- The information provided must be clear, without reference to the vehicle’s handbook or other source.
- There must be no possibility of the users being given false information.
- If, with the ignition on and with engine running or not, the airbag status can be changed, the system must react correctly to the change immediately. Systems will be checked once the vehicle diagnostics/system checks have been completed.
- If at any time the airbag is switched from the OFF position to the ON position, the status indicator showing that the airbag is ON must signal this immediately for at least 60 seconds, regardless of the length of time the ignition has been switched on, or until the ignition is switched off again.

### 3.5.2 Provision of Three-point Seat Belts

If all forward or rearward facing passenger seats are equipped with three-point seatbelts, **1 point** is awarded to the Child Protection score.

### 3.5.3 Gabarit

Where both outboard rear seats, used by a CRS in the crash tests, are in compliance with the following requirements, which are based on, but not identical to, UN ECE Regulation 16.05 [2], **1 point** shall be awarded to the Child Protection score. The Gabarit, as specified in Appendix II, shall be installed on both of the 2<sup>nd</sup> row outboard seats according to the following procedure:

3.5.3.1 Adjust the seat to its fully rearward and lowest position, the seat back to an angle of 25 degrees from the vertical or nearest fixed position and the upper seat belt anchorage to its lowest position.

3.5.3.2 If an alternative seat, seat-back or safety-belt anchorage adjustment is to be used when installing CRS, information about the alternative position must be included in the

- Vehicle Handbook giving the information required in 3.5.4 a). Where this information is provided, set the seat to this position.
- 3.5.3.3 Place a cotton cloth on the seat-back and cushion.
  - 3.5.3.4 Place the Gabarit on the vehicle seat.
  - 3.5.3.5 Arrange the safety-belt strap around the fixture in approximately the correct position as shown in Figures 1 and 2, then latch the buckle.
  - 3.5.3.6 Ensure that the fixture is located with its centreline on the apparent centreline of the seating position  $\pm 25$  mm with its centreline parallel with the centreline of the vehicle.
  - 3.5.3.7 Ensure that all webbing slack is removed. Use sufficient force to remove the slack, do not attempt to tension the webbing.
  - 3.5.3.8 Push rearwards on the centre of the front of the fixture with a force of  $100 \text{ N} \pm 10 \text{ N}$ , applied parallel to the lower surface, and remove the force.
  - 3.5.3.9 Push vertically downwards on the centre of the upper surface of the fixture with a force of  $100 \text{ N} \pm 10 \text{ N}$ , and remove the force.

**INSTALLATION OF FIXTURE ONTO VEHICLE SEAT**

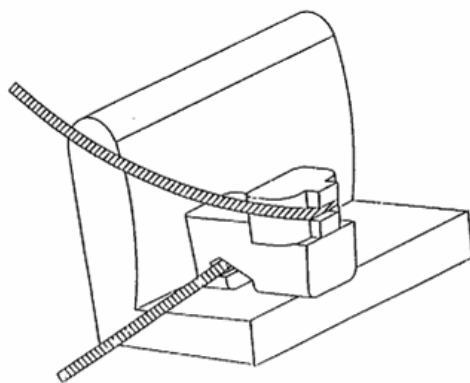

**Figure 1**

**CHECK FOR COMPATIBILITY**

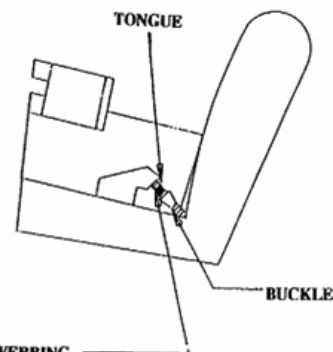

**Note: THE SEAT BELT WEBBING MUST CONTACT THE CURVED EDGE ON BOTH SIDES OF THE FIXTURE**

**LAP BELT ONLY SHOWN**

**Figure 2**

- 3.5.3.10 Requirements:
  - a) With correct routing of the adult seat belt around the Gabarit, the base of the Gabarit shall contact both the forward and rearward parts of the seat cushion upper surface. If such contact does not occur due to the belt access gap in the Gabarit, this gap may be covered in line with the bottom surface of the Gabarit.
  - b) The lap portion of the belt shall touch the fixture on both sides at the rear of the lap belt path.
  - c) There shall be sufficient seat belt webbing to fit around the entire Gabarit while allowing the contact between the Gabarit and both the forward and rearward parts of the seat cushion upper surfaces.

- d) With nothing placed within the adult belt system and with the buckle fastened, it must be possible to establish a tension of at least 50 N in the lap section of the belt by external application of tension in the diagonal section of the belt in the direction of the upper seat belt guide. This may result in movement of the lower anchorages and/or buckles from their anticipated 'design position'. For example, the tension may cause the lap section of the belt to slide between the rear of the seat base and bottom of the seat back, hence shortening the length of the lap section. However, if this is considered to be achievable through 'normal use' then the assessment will be made with the anchorage/buckle in this position.

#### 3.5.4 All Passenger Seats Suitable for Universal CRS

Where the following requirements are complied with, **1 point** shall be awarded to the Child Protection score. The Gabarit shall be installed on the front passenger seat and all remaining rear seats in accordance with the procedure detailed in 3.5.3. If the vehicle is a 2 seater then only the passenger seat is required to meet the requirements.

- a) The Vehicle Handbook indicates that all the passenger seats are suitable for use with a Group 0 and Group 1 Universal CRS (U). ([2], Annex 17, Appendix 3.)
- b) All passenger seats meet the requirements detailed in the Gabarit Section 3.5.3 above.
- c) If an alternative seat, seat-back or safety-belt anchorage adjustment is used for the Gabarit check, information about the alternative position must be included in the Vehicle Handbook table giving the information required in 3.5.4 a).

#### 3.5.5 ISOFIX

##### 3.5.5.1 *Usability*

Where two passenger seats are in compliance with the following requirements, **1 point** shall be awarded to the Child Protection score. If the vehicle is a 2 seater then only the passenger seat or seats is required to meet the requirements.

- a) Each seat which is equipped with ISOFIX anchorages must be marked. It must be clear which pairs of ISOFIX anchorages should be used together.
- b) The location of each ISOFIX anchorage must be marked.
- c) The location of each top tether anchorage must be marked.
- d) The markings must include both text and a pictogram.
- e) The markings must be of conspicuous design and both the text and pictogram must have colours which contrast with their background.
- f) The markings must be permanently visible. Flag type labels are not acceptable.
- g) The marking must be permanently attached to the vehicle.
- h) Each ISOFIX anchorage must be equipped with permanent guidance which physically helps the ISOFIX latches to line up with the anchorages.
- i) It must be possible to fit the top tether easily, without having to carry out any

preparatory actions on the vehicle other than the *simple* opening of a cover over the top tether anchorage, or adjustment of the head restraint position. For example, it would not be acceptable to have to remove the head restraint.

#### 3.5.5.2 *Three or More Positions for Universal ISOFIX*

Where the vehicle is in compliance with the following requirements, **1 point** shall be awarded to the Child Protection score.

- a) Three or more passenger seats are suitable for simultaneous use with a Universal ISOFIX CRS, equipped with a top tether.
- b) All these passenger seats meet the requirements detailed in the “ISOFIX Usability” section above.

#### 3.5.5.3 *Allocations for Largest ISOFIX*

Where the vehicle is in compliance with the following requirements, **1 point** shall be awarded to the Child Protection score.

- a) For vehicles with rear seats, two or more passenger seats are suitable for simultaneous use with the largest size of rearward facing (Class C) ISOFIX CRS, Fixture (CRF) ISO/R3.
- b) For vehicles without rear seats, one or more passenger seats are suitable for simultaneous use with the largest size of rearward facing (Class C) ISOFIX CRS, Fixture (CRF) ISO/R3.
- c) When checking a CRF on a rear seat, the vehicle seat located in front of this rear seat may be adjusted longitudinally forward but not further than the mid position between its rearmost and foremost positions. The seat backrest angle may also be adjusted, but not to a more upright angle than corresponding to a torso angle of 15 degrees.

#### 3.5.6 Integrated CRS

##### 3.5.6.1 *Availability of Integrated CRS*

Where the vehicle is provided with two or more integrated CRS, as standard equipment, **1 point** shall be awarded to the Child Protection score. For vehicles without rear seats, 1 point will be awarded in case one or more passenger seats are provided with integrated CRS.

##### 3.5.6.2 *One or More Group I-III Integrated CRS*

Where the vehicle is provided with one or more “Group I-III” integrated CRS, as standard, **1 point** shall be awarded to the Child Protection score.

*Note: Group I for children of mass from 9kg to 18kg Group II for children of mass from 15kg to 25kg Group III for children of mass from 22kg to 36kg ([1], Paragraph 2.1.1.)*

## **3.6 Scoring and Visualisation**

### **3.6.1 Scoring**

Currently, the maximum number of points available for child protection in vehicles with rear seats is 49. For vehicles without rear seats, the maximum is 23 points (no dynamic and partial vehicle based assessments).

To ensure that all vehicles can be assessed equally and that none are penalised for being a particular body type, i.e. two seater sports car, the relative score weighting of the available assessments remain the same for each assessment are (dynamic performance, marking, compatibility, etc.). This means that for vehicles without rear seats the score out of 23 is called to be equivalent to any other vehicle that is assessed out of 49 points.

The tables below summarise the maximum possible score in each (sub)category for vehicles with limited rear space and for vehicles with no rear seats (such as two seaters).

3.6.2 Child Protection Assessment Points Table (Normal and Limited Rear Space)

Section	Category	Total points	
<b>3.3</b>	<b>Dynamic Assessment</b>	<b>(24)</b>	<b>49%</b>
3.3.1	Ejection	<i>switch</i>	
3.3.2	Head Contact with the Vehicle	<i>switch</i>	
<b>3.3.3</b>	<b>Frontal Impact</b>	<b>(16)</b>	
3.3.3.1	Head Contact with the CRS	6	
3.3.3.2	Head Excursion (Forward Facing CRS)		
3.3.3.3	Head Exposure (Rearward Facing CRS)		
3.3.3.4	Neck Tension (Rearward Facing CRS)	2	
3.3.3.5	Chest	8	
<b>3.3.4</b>	<b>Side Impact</b>	<b>(8)</b>	
3.3.4.1	Head Containment	<i>switch</i>	
3.3.4.2	Head Contact with the CRS	8	
<b>3.4.</b>	<b>CRS Based Assessment</b>	<b>(12)</b>	<b>24%</b>
<b>3.4.1</b>	<b>CRS Marking</b>	<b>(8)</b>	
3.4.1.1	Additional Marking Requirements (ISOFIX CRS)	<i>switch</i>	
3.4.1.2	Additional Marking Requirements (Vehicle Specific CRS)	<i>switch</i>	
<b>3.4.2</b>	<b>CRS to Vehicle Interface</b>	<b>(4)</b>	
3.4.2.1	Additional Interface Requirements (Universal CRS)	<i>switch</i>	
3.4.2.2	Additional Interface Requirements (ISOFIX & other CRS)	<i>switch</i>	
<b>3.5</b>	<b>Vehicle Based Assessment</b>	<b>(13)</b>	<b>27%</b>
<b>3.5.1</b>	<b>Use of CRS on the Front Seat</b>	<b>(8)</b>	
3.5.1.1	Airbag Warning Marking	2	
3.5.1.2	Airbag Disabling	3	
3.5.2	Provision of Three-point Seat Belts	1	
3.5.3	Gabarit	1	
3.5.4	All Passenger Seats Suitable for Universal CRS	1	
<b>3.5.5</b>	<b>ISOFIX</b>	<b>(3)</b>	
3.5.5.1	Usability	1	
3.5.5.2	Three or More Positions for Universal ISOFIX	1	
3.5.5.3	Allocations for Largest ISOFIX	1	
<b>3.5.6</b>	<b>Integrated CRS</b>	<b>(2)</b>	
3.5.6.1	Availability of integrated CRS	1	
3.5.6.2	One or more for Groups I – III	1	

### 3.6.3 Child Protection Assessment Points Table (No Rear Seats)

Section	Category	Total points	
<b>3.3</b>	<b>Dynamic Assessment</b>	<b>Not available</b>	<b>0%</b>
<b>3.4.</b>	<b>CRS Based Assessment</b>	<b>(12)</b>	<b>52%</b>
<b>3.4.1</b>	<b>CRS Marking</b>	<b>(8)</b>	
3.4.1.1	Additional Marking Requirements (ISOFIX CRS)	<i>switch</i>	
3.4.1.2	Additional Marking Requirements (Vehicle Specific CRS)	<i>switch</i>	
<b>3.4.2</b>	<b>CRS to Vehicle Interface</b>	<b>(4)</b>	
3.4.2.1	Additional Interface Requirements (Universal CRS)	<i>switch</i>	
3.4.2.2	Additional Interface Requirements (ISOFIX & other CRS)	<i>switch</i>	
<b>3.5</b>	<b>Vehicle Based Assessment</b>	<b>(11)</b>	
<b>3.5.1</b>	<b>Use of CRS on the Front Seat</b>	<b>(7)</b>	
3.5.1.1	Airbag Warning Marking	2	
3.5.1.2	Airbag Disabling	3	
3.5.2	Provision of Three-point Seat Belts	Not available	
3.5.3	Gabarit	1	
3.5.4	All Passenger Seats Suitable for Universal CRS	1	
<b>3.5.5</b>	<b>ISOFIX</b>	<b>(2)</b>	
3.5.5.1	Usability	1	
3.5.5.2	Three or More Positions for Universal ISOFIX	Not available	
3.5.5.3	Allocations for Largest ISOFIX	1	
<b>3.5.6</b>	<b>Integrated CRS</b>	<b>(2)</b>	
3.5.6.1	Availability of integrated CRS	1	
4.5.6.2	One or more for Groups I – III	1	

3.6.3.1 Where a forward facing (FWF) CRS is recommended for the P1½, the overall score will be reduced by 4.08% for all types of vehicle. This is equivalent to the 2 point reduction (out of 49 points) in the dynamic rating, where a P1½ FWF CRS can only score 10 out of a maximum of 12 points (section 3.3.3).

3.6.3.2 Vehicles without rear seats will automatically score **zero points** in the all Vehicle Based Assessments (section 3.5) except in Integrated CRS (section 3.5.6), where

- a) No form of passenger airbag disabling is offered, or
- b) Dealer disconnection of the passenger airbag is offered either independently or in combination with an airbag switch, regardless whether it meets the requirements of 3.5.1.2.
- c) Only a passenger airbag switch is offered that fails to meet the requirements of 3.5.1.2.

*Note: For 2009 vehicles without rear seats that are equipped as standard with any passenger airbag deactivation switch will be eligible to score in all Vehicle Based Assessments excluding 3.5.1.2.*

#### 3.6.4 Visualisation

The results of the child protection assessment are not visualised.

## 4 CONCEPTS AND EXPLANATIONS BEHIND THE ASSESSMENTS

### 4.1 Dynamic Assessment

#### 4.1.1 Ejection (section 3.3.1)

**CONCEPT:** *The child should be held securely in the restraint and not be ejected from the restraint.*

Ejection is an unusual and highly undesirable situation. The idea of “partial ejection” has been included to allow Euro NCAP to deal with situations where the dummy is only partly held within the restraint, such as: by a foot under the impact shield.

#### 4.1.2 Frontal Impact

##### 4.1.2.1 *Head Exposure (Rearward Facing CRS) (Section 3.3.3.3)*

**CONCEPT:** *The CRS shell must be in a position to provide some energy absorption between the child’s head and an intruding object at all times during the forward excursion of the dummy.*

#### 4.1.3 Side Impact

##### 4.1.4 Head Containment (Section 3.3.4.1)

**CONCEPT:** *The CRS shell must be in a position to provide some energy absorption between the child’s head and an intruding vertical plane striking the seat from the struck side.*

### 4.2 CRS Based Assessment

#### 4.2.1 CRS Marking (Section 3.4.1)

**CONCEPT:** *The information provided on the child seat should be sufficient to allow the user to correctly install the restraint. Such information should be clear, always visible to the user and last the life of the seat.*

**CONCEPT:** *Users of child seats that can be used rearward-facing should be clearly informed and reminded of the risks posed, by a frontal protection air bag, to the occupants of such seats.*

##### 4.2.1.1 Additional Marking (Vehicle Specific) (Section 3.4.1.2)

**CONCEPT:** *The user of a Vehicle Specific or Semi-universal ISOFIX restraint should be aware of the fact that the seat is only approved for use in a limited number of named vehicles.*

#### 4.2.2 CRS to Vehicle Interface (Section 3.4.2)

**CONCEPT:** *The child seat should be compatible with the methods of fixation in the vehicle recommended by the car manufacturer.*

### **4.3 Vehicle Based Assessment**

#### **4.3.1 Use of CRS on Front Seat**

##### **4.3.1.1 Airbag Warning Marking (Section 3.5.1.1)**

**CONCEPT:** *A warning regarding the hazard posed by a frontal protection air bag to the occupant of a rearward-facing child restraint should be permanently and explicitly marked on the vehicle and be designed to last the lifetime of the vehicle.*

##### **4.3.1.2 Airbag Disabling Requirements (Section 3.5.1.2)**

**CONCEPT:** *The vehicle should make provision for the safe carrying of a child in a rearward facing CRS in the front passenger seat, ideally without additional actions by the installer.*

**CONCEPT:** *Where a manual switch is used to disable the airbag, Precautions should be taken to ensure that the switch cannot be operated by a child, without the knowledge of the driver.*

#### **4.3.2 Provision of Three-point Seat Belts (Section 3.5.2)**

**CONCEPT:** *All forward or rearward facing seats should be equipped with a three-point belt.*

#### **4.3.3 Gabarit (Section 3.5.4)**

**CONCEPT:** *The layout of the adult seat belt should ensure compatibility between the adult seat belt and a Universal CRS.*

#### **4.3.4 All Passenger Seats Suitable for Universal CRS (Section 3.5.4)**

**CONCEPT:** *All possible seating positions should be capable of providing a good interface with a conventional Universal child seat, secured by an adult seat belt.*

#### **4.3.5 ISOFIX**

##### **4.3.5.1 Usability (Section 3.5.5.1)**

**CONCEPT:** *The user of a vehicle equipped with ISOFIX anchorages should be made aware of the existence and location of the anchorages, including any top tether anchorages. There should also be permanent guidance to facilitate the correct installation of the CRS.*

##### **4.3.5.2 Three or More Positions for Universal ISOFIX (Section 3.5.5.2)**

**CONCEPT:** *Vehicles that provide three or more seating positions suitable for a Universal ISOFIX CRS equipped with top tether should be rewarded.*

4.3.5.3 Two or More Positions for Largest ISOFIX (Section 3.5.5.3)

**CONCEPT:** *Vehicles in which at least two ISOFIX positions are capable of accommodating the largest size of rearward-facing ISOFIX CRS should be rewarded.*

4.3.6 Integrated CRS

4.3.6.1 Two or More Integrated CRS (Section 3.5.6.1)

**CONCEPT:** *Vehicles that provide, as standard, two or more integrated restraints should be rewarded.*

4.3.6.2 One or More Group I-III Integrated CRS (Section 3.5.6.2)

**CONCEPT:** *Vehicles that offer at least one integrated restraint suitable for all age groups except the youngest children, who use portable restraint systems, should be rewarded.*

## **5 REFERENCES**

- 1 UN ECE Regulation 44, Revision 2, “Uniform Provisions Concerning The Approval Of Restraining Devices For Child Occupants Of Power-Driven Vehicles ("Child Restraint System)”, 4 February 2008.
- 2 UN ECE Regulation 16 Revision 05 “Uniform Provisions Concerning The Approval Of: I. Safety-Belts, Restraint Systems, Child Restraint Systems And ISOFIX Child Restraint Systems For Occupants Of Power-Driven Vehicles; II. Vehicles Equipped With Safety-Belts, Restraint Systems, Child Restraint Systems and ISOFIX Child Restraint Systems”, 24 February 2005.

# APPENDIX I

## CHILD OCCUPANT ASSESSMENT OVERVIEW

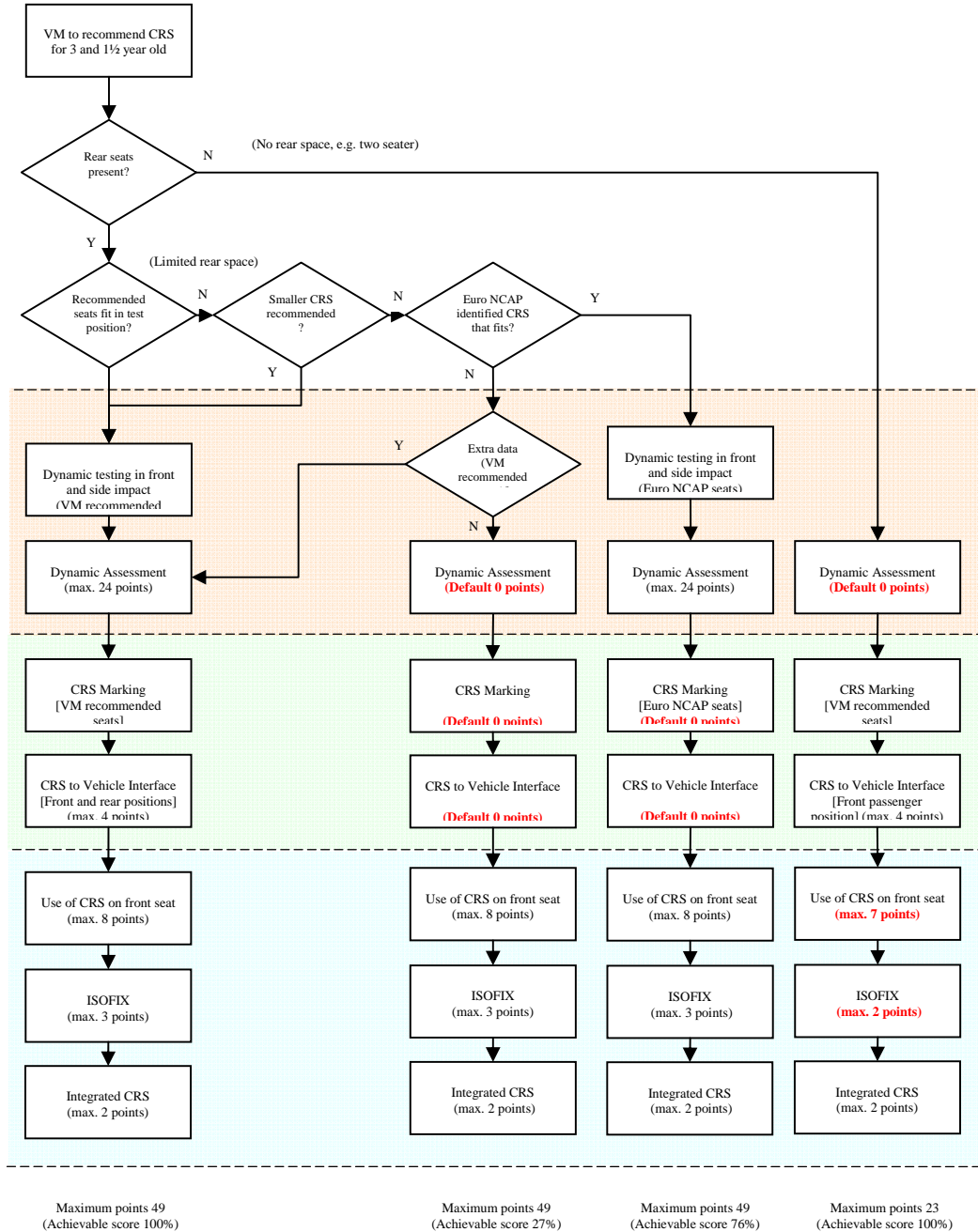

## APPENDIX II

### Gabarit specification

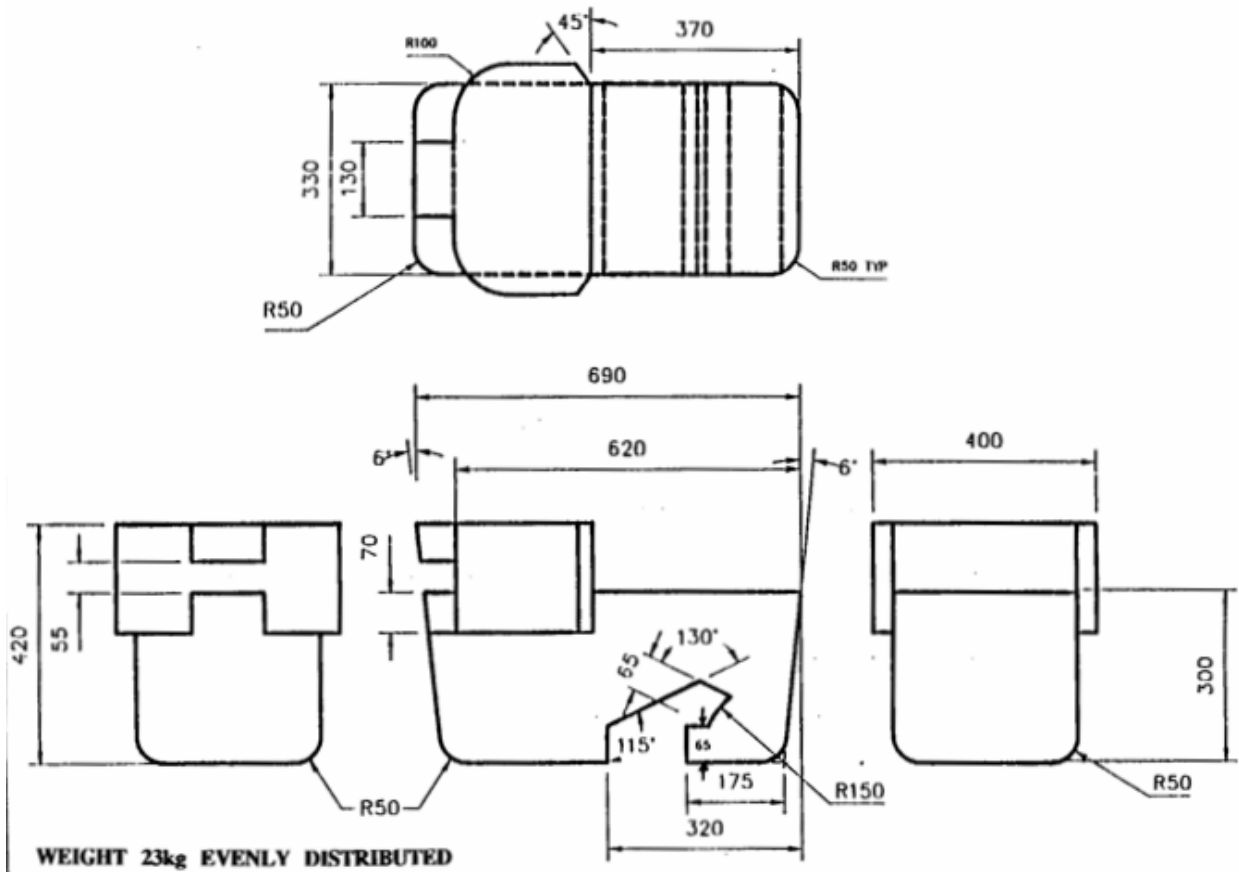

All dimensions are in mm